



AERONEX® SK SERIES GAS PURIFICATION SYSTEM

Continuous ultrapure NH₃ gas at a low cost of ownership



continuous ultrapure NH₃ gas at a low cost of ownership

Overview

The Aeronex® SK Series removes gaseous contaminants such as H₂O, CO₂ and O₂ to sub-ppb levels in ammonia. The systems utilize ambient temperature purification technology, have a low pressure drop and offer a low cost of ownership.

With the Aeronex® SK Series system, all purifiers used in a process are integrated into a single, microprocessor-controlled cabinet with a touch screen interface. The systems use two purifier beds in order to maintain a continuous flow of pure gas. One purifier bed is on-line while the other is in regeneration or is ready for use. Contaminants are removed to sub-ppb (part-per-billion) and ppt (part-per-trillion) levels.

All functions such as conditioning and purging are completely automated, requiring minimal user interface and providing maximum reliability and cost of ownership. The system offers improved safety by placing all purifiers in a single location and, because the purifiers are regenerable, there are no environmental concerns.

Panel-mounted subsystems are offered specifically to OEMs and are designed for integration into a process tool.

Applications

- Metallorganic Chemical Vapor Deposition (MOVCD)
- Other applications that require ultrapure NH₃

Features and Benefits

- Power failure will not damage the purification system
- Complete automatic operation saves time, increases reliability
- Purifies to sub-ppb (part-per-billion) and ppt (part-per-trillion) levels
- Low pressure drop means no changes to inlet pressure are required
- Self-regenerating purifiers provide the lowest cost of ownership
- Ambient temperature purification means lower energy costs and resource conservation
- CE and SEMI® S2 certified
- Start-up service is provided, making it easy to integrate the unit
- The system is designed for easy field maintenance and upgrades
- Available worldwide through Entegris' global infrastructure

Models Available

Model	Description
PGPS4SK	Panel-mounted model for OEM use and for applications requiring a flow rate up to 120 SLM
EGPS4SK	Enclosed model for use with applications requiring a flow rate up to 120 SLM
EGPS8SK	Enclosed model for use with applications requiring a flow rate up to 300 SLM

System Process and Instrumentation Diagram

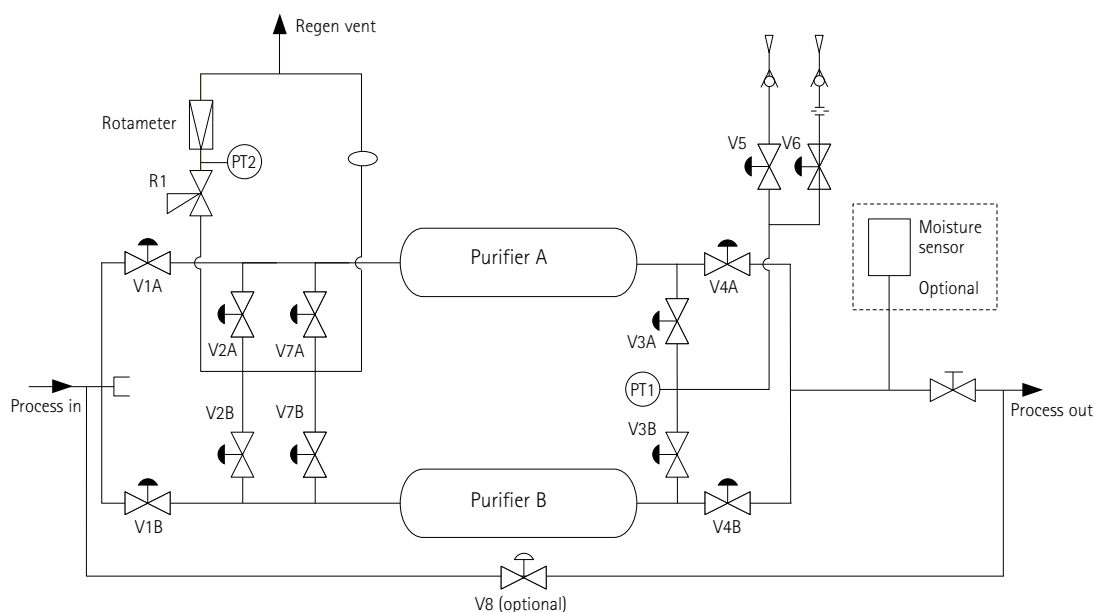

Safety Features

Feature	Description	PGPS4	EGPS4	EGPS8
Circuit breaker	Provides additional electrical protection to the system and includes a lock-out/tag-out.	N/A	Yes	Yes
Over temperature rise condition	Monitored via thermocouple. Heaters sized to prevent runaway conditions. As a secondary precautionary device, a high-temperature hardware interlock is included on the EGPS4.	Yes	Yes	Yes
Hydrogen detector	Triggers an EMO alarm and shuts down the system in the event of a gas leak of hydrogen inside system enclosure.	N/A	Yes	Yes
Rate-of-rise detector	If the detector senses a rapid increase in temperature inside the system enclosure, an EMO alarm will be activated and shut down the system.	N/A	Yes	Yes
EMO button	When activated, power is removed from the cabinet. The system shuts down. The front panel and controller remain powered.	N/A	Yes	Yes
Remote EMO	Provides input for remote EMO activation and an output for remote signal of EMO condition.	Yes	Yes	Yes
Remote alarm	In the event of a minor alarm in the system not requiring an EMO shutdown, the system will send a signal to an external sensing device that alerts the facility of the alarm.	Yes	Yes	Yes
Visual alarm	In the event of an alarm, a detailed description of the alarm will be displayed in red on systems that include a touch screen. In the event of an alarm on a system with LEDs, a red LED indicator will activate.	Yes	Yes	Yes
Audible alarm	Alarm conditions result in an audible alarm.	N/A	Yes	Yes
Static pressure switch/door interlock	Monitors system for adequate static pressure. If enclosure ventilation falls below acceptable levels, an alarm is generated in the system; also serves as a door interlock to prevent the system from being used while the door is opened.	N/A	Yes	Yes
Isolated electrical enclosure	Electronics are physically isolated from the main purifier cabinet in an attached electrical enclosure in situations where high-voltage lines are near potentially flammable gas. Low-voltage components located inside the enclosure are SELV (Safety Extra Low Voltage).	N/A	Yes	Yes
Single or dual contained plumbing interface	Allows end user to use either single or dual contained plumbing for installation.	Yes	Yes	Yes

Product Specifications

Model	PGPS4	EGPS4	EGPS8
Gases purified	NH ₃		
Media type	Inorganic		
Contaminants removed	H ₂ O, CO ₂ and O ₂		
Outlet purity	<1 part-per-billion (ppb)		
Operating pressure range	515–1825 kPa (60–250 PSIG)		
Pressure drop	<15 PSI @ 120 PSIG inlet and max rated flow		
Maximum flow rate	120 SLM		300 SLM
Gas operating temperature	-40°C to +60°C (-40°F to +150°F)		
Outlet filtration	0.003 micron @ 99.9999999% efficiency		
Leak rating	1 × 10 ⁻⁹ atm cc/sec.		

Facility Specifications

Specifications		PGPS4	EGPS4	EGPS8
Process gas input	Mechanical connection	1/4" face seal	1/4" tube stub	1/2" tube stub
Process gas output	Mechanical connection	1/4" face seal	1/4" tube stub	1/2" tube stub
Ventilation	Mechanical connection	N/A	4" duct	
	Exhaust flow	N/A	50 CFM	100 CFM
Power requirements	Mechanical connection	Standard terminal		
	Power requirements	200–240 VAC		
	Power consumption	50W at idle and process mode; 300W during regen		50W at idle and process mode; 800W during regen
Regeneration	Max regen frequency	3 days (may be configured per customer inlet gas purity)		
	Regen duration	48 hours		
Regen gas input 1	Gas	N ₂ 515–929 kPa (60–120 PSIG)		
	Mechanical connection	1/4" face seal		1/4" tube stub
Regen gas input 2	Gas	N ₂ , 515–929 kPa (60–120 PSIG)		
	Mechanical connection	1/4" tube stub		
Regen gas output	Pressure	Atmospheric		
	Mechanical connection	1/4" face seal	1/4" tube stub	
Instrument air	Gas and pressure	CDA or N ₂ @ 653–791 kPa (80–100 PSIG)		
	Mechanical connection	1/4" compression fitting		
Physical requirements	Mounting	Wall		Floor
	Shipping weight	32 kg (70 lbs)	39 kg (85 lbs)	113 kg (250 lbs)
	Operating conditions	15°–40°C indoor (60°–104°F indoor)		
	Humidity	10–90% RH noncondensing		

It is the customer's responsibility to ensure that the equipment is installed according to local building code requirements.

Model PGPS4

Dimensional Information

Front view

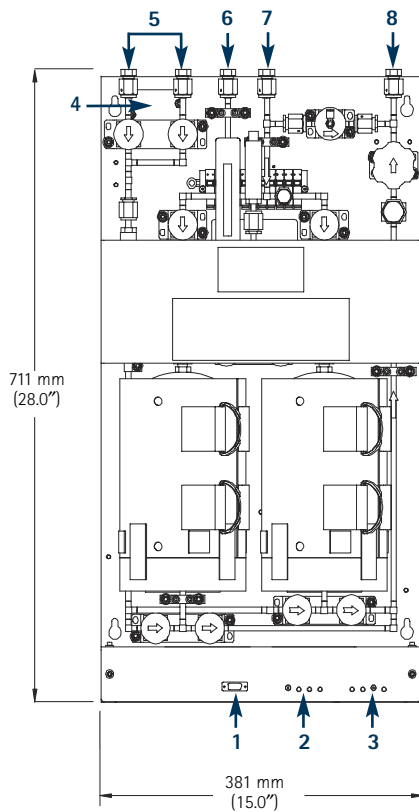

Side view

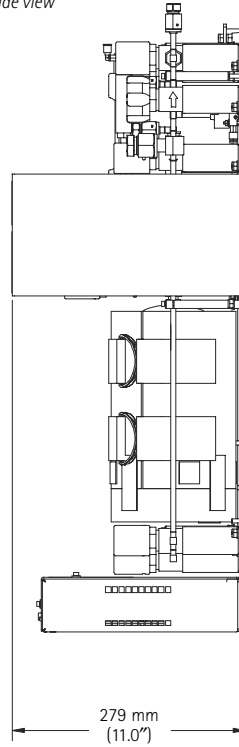

Top view

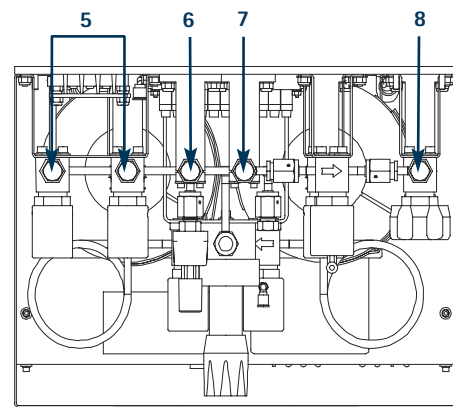

System Connections

1	Communications port	For user interface via PC
2	LED indicators	For main power, bed online, bed regen, heaters and alarms
3	Start	Used to begin system operations and to clear alarms
4	A/C terminal block	Power connection
5	Regen gas input	Inlet for nitrogen and hydrogen used in regen process
6	Gas exhaust/regen vent	Exhausts regen gas
7	Process gas input	Inlet gas (not purified)
8	Process gas output	Outlet gas (purified)

Panel Information

This equipment is not enclosed. It is the user's responsibility to ensure that it is installed in compliance with local safety requirements for gas equipment. The PGPS4 is designed using SEMI® S2 guidelines for gas equipment enclosures. Because it is a subsystem, it must be certified with the final product in which it is used.

Model EGPS4

Dimensional Information

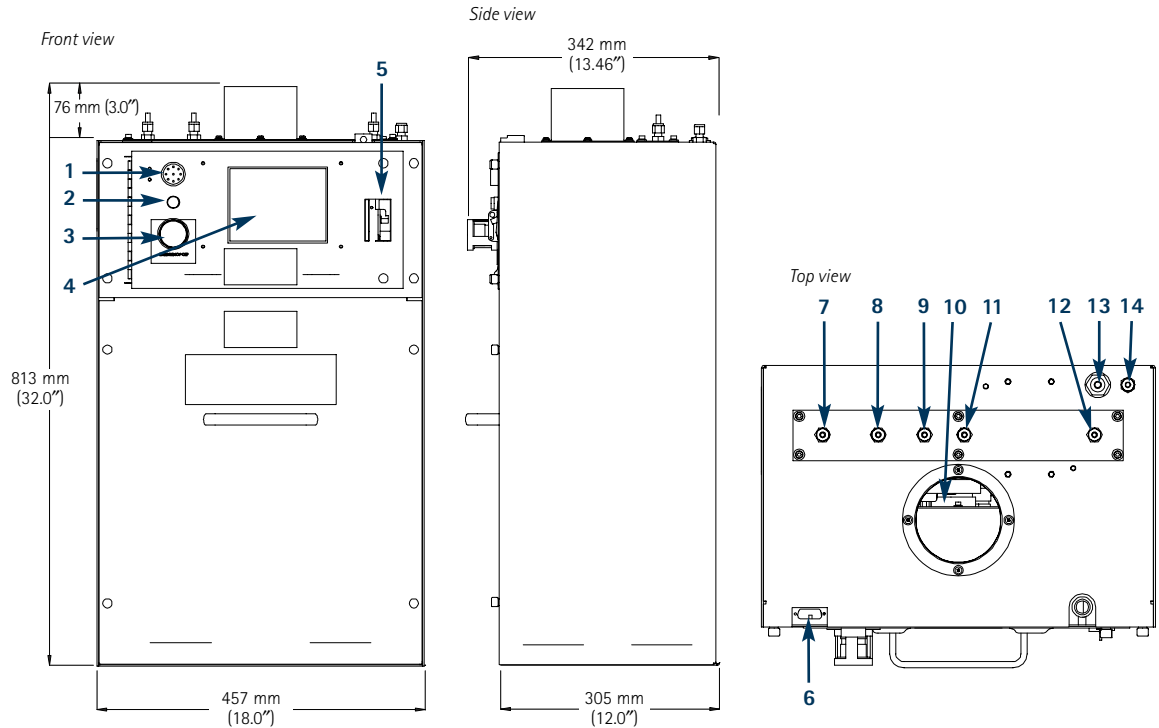

System Connections

1	Audible alarm	Audible warning informs of alarm condition
2	Start	Used to begin system operations and to clear alarms
3	EMO	When activated, power is removed from the cabinet. The system shuts down. Front panel and controller remain powered.
4	Touch screen	For system status and interface
5	Circuit breaker	Provides additional electrical protection to the system and in some models also acts as an ON/OFF switch for the system
6	Remote alarm interface	Allows for remote alarm input and output with female 15 pin DB connector
7	Regen gas input 1	Nitrogen input
8	Regen gas input 2	Hydrogen input
9	Regen gas vent	Exhausts regen gas
10	Exhaust vent	Allows ventilation
11	Process gas input	Inlet gas (not purified)
12	Process gas output	Outlet gas (purified)
13	Reference	Atmospheric reference for the internal enclosure flow sensor
14	Instrument air	Supplies gas to the air operated control valves

Enclosure Information

The ventilated enclosure is designed for indoor applications only. The enclosure has mounting locations on the back surface. The front panel is removable.

Model EGPS8

Dimensional Information

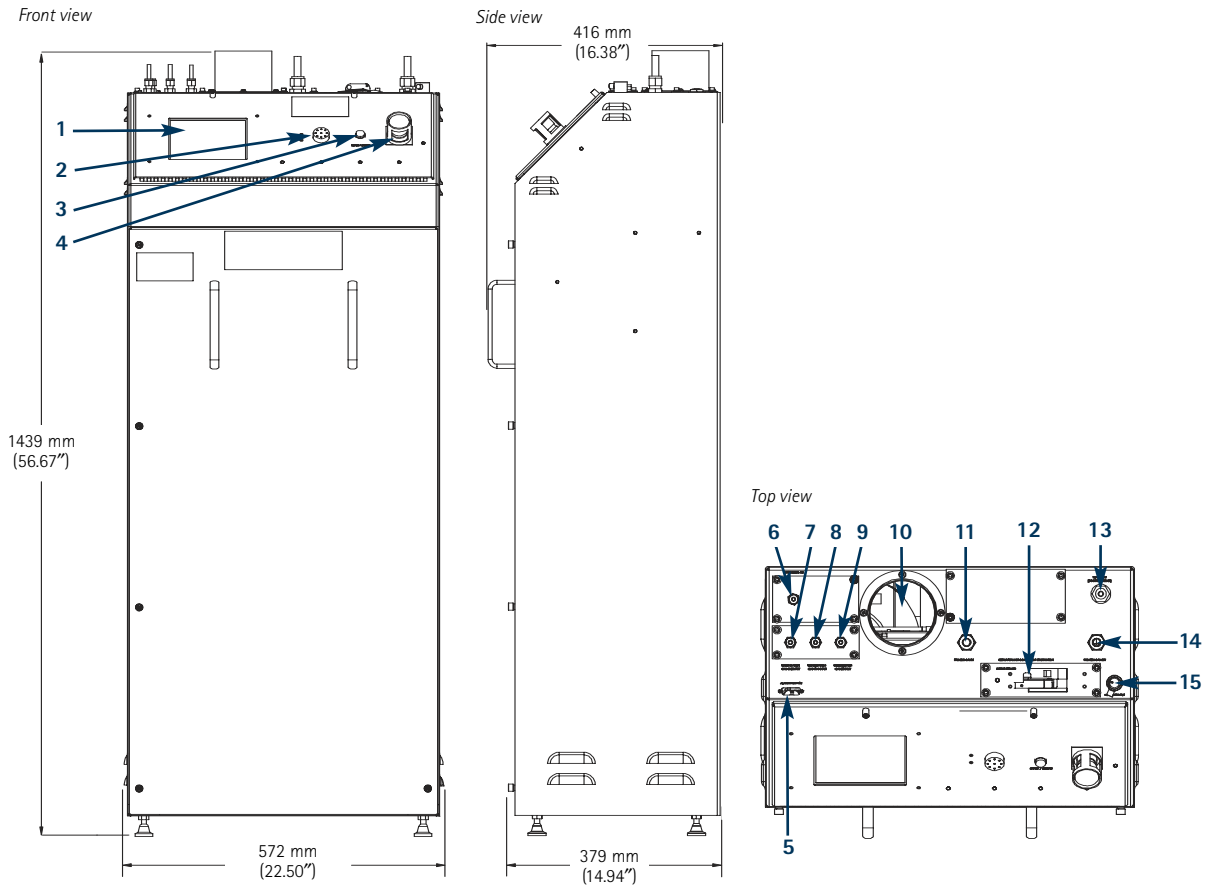

System Connections

1	Touch screen	For system status and interface
2	Audible alarm	Audible warning informs of alarm condition
3	Start	Used to begin system operations and to clear alarms
4	EMO	When activated, power is removed from the cabinet. The system shuts down. Front panel and controller remain powered.
5	Remote alarm interface	Allows for remote alarm input and output with female 15 pin DB connector
6	Instrument air	Supplies gas to the air-operated control valves
7	Regen gas input 1	Nitrogen input
8	Regen gas input 2	Hydrogen input
9	Regen gas vent	Exhausts regen gas
10	Exhaust vent	Allows ventilation
11	Process gas input	Inlet gas (not purified)
12	Circuit breaker	Provides additional electrical protection to the system and in some models also acts as an ON/OFF switch for the system
13	Reference	Atmospheric reference for the internal enclosure flow sensor
14	Process gas output	Outlet gas (purified)
15	A/C power input	Power connection

Enclosure Information

The ventilated enclosure is designed for indoor applications only. The enclosure has mounting locations on the back surface. The front panel is removable.

Options

Available Options	Letter (Designator)	PGPS4	EGPS4	EGPS8
Automatic bypass manifold	A	Yes	Yes	Yes
Manual bypass manifold	M	Yes	N/A	Yes

Ordering Information

Part Number

PGPS4	EGPS4	EGPS8
Panel-mounted model for OEM use and applications requiring a flow rate up to 120 SLM	Use with applications requiring a flow rate up to 120 SLM	Use with applications requiring a flow rate up to 300 SLM
PGPS4SK	EGPS4SK	EGPS8SK
PGPS4SKA	EGPS4SKA	EGPS8SKA
PGPS4SKM	N/A	EGPS8SKM

Part Number	Automatic Bypass Manifold	Manual Bypass Manifold
PGPS4SK		
PGPS4SKA	Yes	
PGPS4SKM		Yes
EGPS4SK		
EGPS4SKA	Yes	
EGPS8SK		
EGPS8SKA	Yes	
EGPS8SKM		Yes

Specifications are subject to change.
Please verify prior to order.

For More Information

Please call your Regional Customer Service Center today to learn what Entegris can do for you. Visit www.entegris.com and select "Regional Customer Service Centers" for the center nearest you.

Terms and Conditions of Sale

All purchases are subject to Entegris' "Terms and Conditions of Sale." To view and print this information, visit Entegris' Web site at www.entegris.com and select the Legal Notices link from the footer found on the home page.



Entegris®, Aeronex® and XCDA® are registered trademarks of Entegris, Inc.
Semi® is a registered trademark of Semiconductor Equipment and Materials International.
U.S. Patent No. 6,524,544.

ENTEGRIS, INC.

Corporate Headquarters / 3500 Lyman Boulevard / Chaska, Minnesota 55318 USA
Customer Service Tel. 952-556-4181 / Customer Service Fax 952-556-8022
www.entegris.com